

9. In a hydrogen atom an electron moves in an orbit of radius $5.0 \times 10^{-11} \text{ m}$ with a speed of $2.2 \times 10^6 \text{ m/sec}$. Find the equivalent current: (Electronic charge = $1.6 \times 10^{-19} \text{ C}$).

- (a) 11.2 mA (b) 1.12 mA (c) $7.04 \times 10^{-3} \text{ A}$ (d) None of these

10. A wire of resistance R is coiled in the form of circle. Then the equivalent resistance between points A and B is:

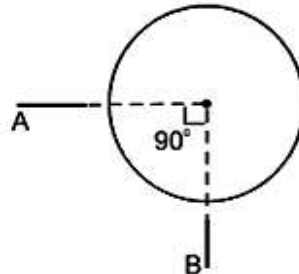

- (a) $\frac{R}{16} \Omega$ (b) $\frac{3R}{16} \Omega$ (c) $\frac{3R}{4} \Omega$ (d) $\frac{4}{3} \Omega$

11. What is the sure evidence of a permanent magnet:

- (a) Repulsion (b) Attraction (c) Both A & B (d) Neither A nor B

12. The resistance of a wire is R . After melting it is remoulded such that its area of cross-section becomes n times its initial area of cross-section, its new Resistance will be

- (a) nR (b) $\frac{R}{n}$ (c) $n^2 R$ (d) $\frac{R}{n^2}$

13. What is the equivalent resistance of the network between points A and B? (each resistance is of value r).

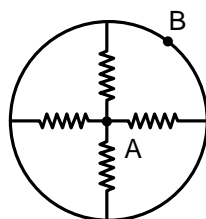

- (a) $\frac{r}{2}$ (b) $4r$ (c) $\frac{r}{4}$ (d) zero

14. The current in the circuit shown below is

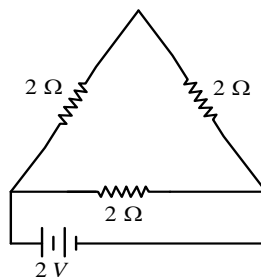

- (a) 1.5 A (b) 0.5 A (c) 2.5 A (d) 0.66 A

15. Which of the following figures represents the magnetic lines of force due to an isolated north pole?

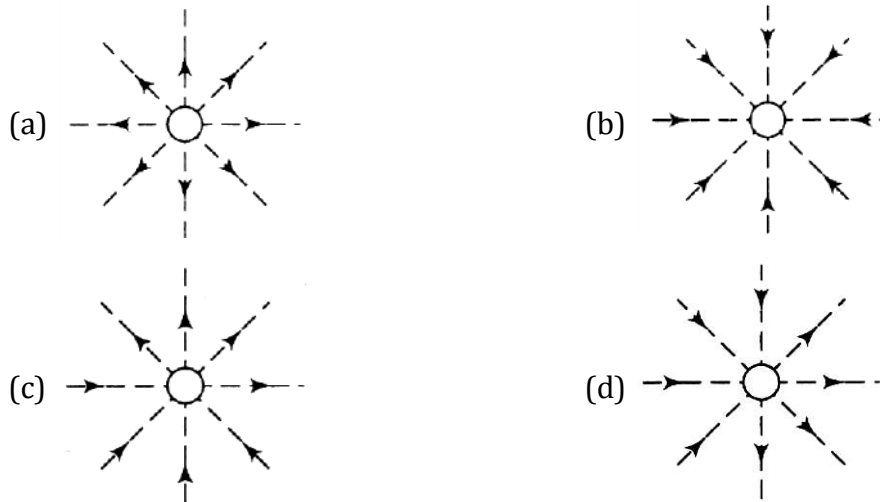

16. A magnetic field exerts no force on:

- (a) An electric charge moving perpendicular to its direction
- (b) An unmagnetised iron bar
- (c) A stationary electric charge
- (d) A magnet

17. A certain length of wire carries a steady current. It is bent to form a circular coil of one turn. The same length is now bent more sharply to give a double loop of smaller radius, as shown in figure. The magnetic field at the centre caused by the same current is

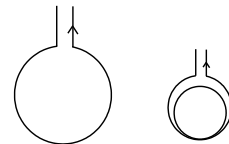

- (a) A quarter of its first value
- (b) Unaltered
- (c) Four times its first value
- (d) One half its first value

18. From a power – station, the power is transmitted at a very high voltage because:

- (a) It is generated only at high voltage
- (b) It is cheaper to produce electricity at high voltage
- (c) Electricity at high voltage is less dangerous
- (d) There is less loss of energy in transmission at high voltage

19. The refractive indices of glass and water are $\frac{5}{3}$ and $\frac{4}{3}$ respectively. For a ray of light moving from glass to water, critical angle will be :

- (a) $\sin^{-1} \frac{4}{5}$
- (b) $\sin^{-1} \frac{3}{5}$
- (c) $\sin^{-1} \frac{3}{2}$
- (d) $\sin^{-1} \frac{2}{1}$

20. An object is placed at the centre of curvature of concave mirror. Its image is formed at

- (a) Infinite (b) centre of curvature
(c) principal focus (d) pole of the concave mirror

21. Light passes from glass to air. In which of the following cases critical angle is minimum?

- (a) Red colour light (b) Green colour light
(c) Yellow colour light (d) Blue colour light

22. Three lenses have a combined power of 2.7 D. If the powers of two lenses are 2.5 D and 1.7 D respectively, find the focal length of the third lens :

- (a) -66.66 cm (b) -6.666 cm
(c) -66.66 m (d) -6.666 m

23. In the given ray diagram correct relation for Snell's law is :

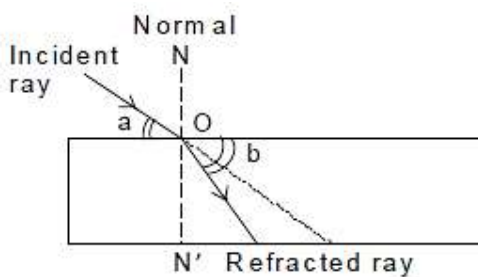

- (a) $\frac{\sin a}{\sin b} = \text{constant}$ (b) $\frac{\sin b}{\sin a} = \text{constant}$
(c) $\frac{\sin(90-a)}{\sin(90-b)} = \text{constant}$ (d) $\frac{\sin(90-a)}{\sin b} = \text{constant}$

24. Three bulbs with individual power ratings of 12W, 2 W and 6 W respectively are connected as per the circuit diagram below. Find the amount of heat dissipated by each in 10 seconds.

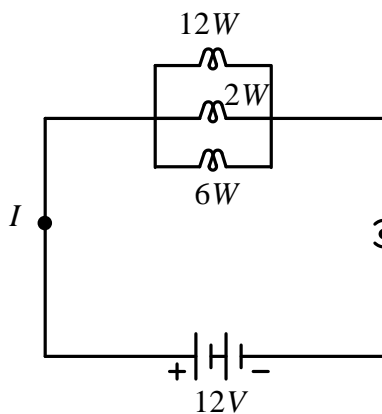

- (a) 8J, 1.33J, 4J (b) 120J, 20J, 60J (c) 10J, 0.277J, 2.5J (d) 12J, 1.66J, 5J

25. Resistors are connect as shown in the circuit diagram. The effective resistance between A and B is

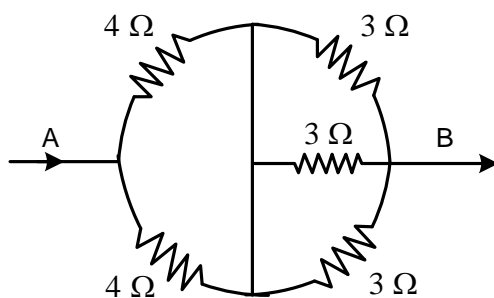

- (a) 3Ω (b) 3.5Ω (c) 11Ω (d) 5.5Ω

CHEMISTRY

26. Methyl orange is

- (a) Pink in acidic medium, yellow in basic medium
(b) Yellow in acidic medium, pink in basic medium
(c) Colourless in acidic medium, pink in basic medium
(d) Pink in acidic medium, colourless in basic medium

27. The nature of calcium phosphate is present in tooth enamel is

- (a) Basic (b) Amphoteric (c) Acidic (d) Neutral

28. The chemical formula of caustic potash is

- (a) NaOH (b) $\text{Ca}(\text{OH})_2$ (c) NH_4OH (d) KOH

29. The function of quick lime in soda lime mixture is to

- (a) Absorb moisture present in soda lime (c) Increase the pH of soda lime
(b) Increase the efficiency of soda lime (d) Take part in reaction with NaOH

30. Which one of the following salts does not contain water of crystallisation?

- (a) Blue vitriol (b) Baking soda (c) Washing soda (d) Gypsum

31. Which information is not conveyed by a balanced chemical equation?

- (a) Physical states of reactants and products
(b) Symbols and formulae of all the substances involved in a particular reaction
(c) Number of atoms/molecules of the reactants and products formed
(d) Whether a particular reaction is actually feasible or not

32. Chemically rust is

- (a) hydrated ferrous oxide (c) hydrated ferric oxide
(b) only ferric oxide (d) none of these

- 33.** The electrolytic decomposition of water gives H_2 and O_2 in the ratio of
(a) 1 : 2 by volume (c) 8 : 1 by mass
(b) 2 : 1 by volume (d) 1 : 2 by mass
- 34.** In the decomposition of lead (II) nitrate to give lead (II) oxide, nitrogen dioxide and oxygen gas, the coefficient of nitrogen dioxide (in the balanced equation) is
(a) 1 (b) 2 (c) 3 (d) 4
- 35.** On immersing an iron nail in $CuSO_4$ solution for few minutes, you will observe
(a) no reaction takes place
(b) the colour of solution fades away
(c) the surface of iron nails acquire a black coating
(d) the colour of solution changes to green
- 36.** Identify the group which is not a Dobereiner triad
(a) Li, Na, K (c) Ca, Sr, Ba
(b) Be, Mg, Cr (d) Cl, Br, I
- 37.** An element with atomic number will form a basic oxide
(a) 7 (b) 17 (c) 14 (d) 11
- 38.** Upto which element, the Law of Octaves was found applicable?
(a) Oxygen (c) Cobalt
(b) Calcium (d) Potassium
- 39.** In Mendeleev's Periodic Table, gaps were left for the elements to be discovered later. Which of the following elements found a place in the Periodic Table later?
(a) Chlorine (c) Oxygen
(b) Silicon (d) Germanium
- 40.** What is the atomic number of element of period 3 and group 17 of the Periodic Table?
(a) 10 (b) 4 (c) 17 (d) 21
- 41.** Which of the following is the correct arrangement of the given metals in ascending order of their reactivity?
Zinc, Iron, Magnesium, Sodium
(a) Zinc > Iron > Magnesium > Sodium (c) Sodium > Zinc > Magnesium > Iron
(b) Sodium > Magnesium > Iron > Zinc (d) Sodium > Magnesium > Zinc > Iron
- 42.** The highly reactive metals like Sodium, Potassium, Magnesium, etc. are extracted by the
(a) electrolysis of their molten chloride (c) reduction by aluminium
(b) electrolysis of their molten oxides (d) reduction by carbon

43. Oxides of moderately reactive metals like Zinc, Iron, Nickel, Tin, Copper etc. are reduced by using
- (a) Aluminium as reducing agent (c) Carbon as reducing agent
 (b) Sodium as reducing agent (d) Calcium as reducing agent
44. In thermite welding a mixture of and is ignited with a burning magnesium ribbon which produces molten iron metal as large amount of heat is evolved.
- (a) iron (III) oxide and aluminium powder (c) iron (III) chloride and aluminium powder
 (b) iron (II) oxide and aluminium powder (d) iron (III) sulphate and aluminium powder
45. Copper objects lose their shine and form green coating of
- (a) Copper oxide (c) Basic Copper carbonate
 (b) Copper hydroxide and Copper oxide (d) Copper carbonate
46. The number of isomers of pentane is
- (a) 2 (b) 3 (c) 4 (d) 5
47. Which of the following will undergo addition reactions?
- (a) CH_4 (b) C_3H_8 (c) C_2H_6 (d) C_2H_4
48. In diamond, each carbon atom is bonded to four other carbon atoms to form
- (a) a hexagonal array (c) a structure in the shape of a football
 (b) a rigid three-dimensional structure (d) a structure of a ring
49. Give the IUPAC name of $\text{CH}_3\text{CH}_2\text{COOC}_2\text{H}_5$
- (a) Ethyl propanoic acid (c) Propyl ethanoate
 (b) Ethyl ethanoate (d) Ethyl propanoate
50. Which is denatured spirit?
- (a) ethanol only (c) ethanol and methanol (5%)
 (b) ethanol and methanol (50%) (d) methanol only

MATHEMATICS

51. If m is any positive integer, then the last two digits in the expression $(81)^m(121)^m - 1$ are
- (a) 02 (b) 10 (c) 20 (d) 00
52. If $a + b + c = 0$, then $\frac{a^4+b^4+c^4}{a^2b^2+b^2c^2+c^2a^2}$ is equal to
- (a) 4 (b) 2 (c) 1 (d) 16
53. If $x = a^2 - bc, y = b^2 - ca, z = c^2 - ab$, then what is the value of $\frac{ax+by+cz}{(a+b+c)(x+y+z)}$
- (a) 0 (b) 1 (c) 2 (d) 4

54. If from the top of a tower 50m high, the angles of depression of two objects are respectively 60° and 45° , then the approximate distance between the objects, is: (objects are on the same side of the tower)

- (a) $50(\sqrt{2} - 2)$ m (b) $50(\sqrt{3} - 3)$ m
 (c) 31m (d) None of these

55. A cone of semi-vertical angle α is inscribed in a sphere of radius 2cm. The height of the cone is:

- (a) $2(1 + \sin 2\alpha)$ (b) $2(1 + \cos 2\alpha)$
 (c) $4\sin \alpha$ (d) $4\cos \alpha$

56. In $\triangle ABC$, $AB = 8$ cm, $AC = 6$ cm, altitude $AD = 4.8$ cm. AE is the diameter of the circumcircle. Find the circumradius.

- (a) 5cm (b) 15cm
 (c) 10cm (d) Can't be determined

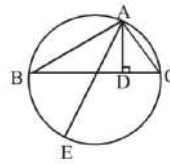

57. In the following figure, PR and SQ are chords, of the circle with centre O , intersecting at T and $TQ = x$ and $TP = y$, then $\frac{(TS+TR)}{(TS-TR)} =$

- (a) $\frac{x}{y}$ (b) $\frac{(x+y)}{(x^2+y^2)}$
 (c) $\frac{(x+y)}{(y-x)}$ (d) $\frac{(x^2+y^2)}{(x^2-y^2)}$

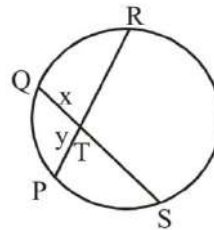

58. In the figure, a semi-circle with centre O is drawn on AB . The ratio of the larger shaded area to the smaller shaded area is:

- (a) $\frac{4\pi-2\sqrt{3}}{2\pi-2\sqrt{3}}$ (b) $\frac{4\pi-3\sqrt{3}}{3\pi-3\sqrt{3}}$
 (c) $\frac{4\pi-3\sqrt{3}}{2\pi-3\sqrt{3}}$ (d) $\frac{3\pi-2\sqrt{3}}{2\pi-2\sqrt{3}}$

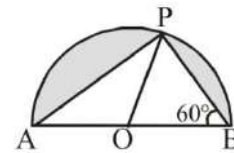

59. If $\sin \alpha = \frac{1}{3}$, then the value of $2\cot^2 \alpha + 2$ is:

- (a) 6 (b) 9 (c) 18 (d) 4

60. The angle of elevation of the top of an unfinished tower from a point at a distance of 120m from its base is 45° . The height of the tower that must be raised so that the angle of elevation at the same point will be 60° is:

- (a) $120(\sqrt{3} - 1)$ m (b) $120(\sqrt{3} + 1)$ m
 (c) $120\sqrt{3}$ m (d) $140\sqrt{3}$ m

61. In the figure ABC is a right-angled triangle right-angled at A . Semicircles are drawn on AB , AC and BC as diameters. Find the area of the shaded region.

- (a) 6sq. unit (b) 9sq. unit
 (c) 8sq. unit (d) 5sq. unit

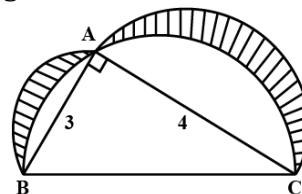

71. If the mean of a, b, c is M and $ab + bc + ca = 0$, the mean of a^2, b^2, c^2 is KM^2 then find the value of $K =$
 (a) 1 (b) 2 (c) 3 (d) 4
72. There are 50 marbles of three colours: blue, yellow and black. The probability of picking up a blue marble is $\frac{3}{10}$ and that of picking up a yellow marble is $\frac{1}{2}$. The probability of picking up a black marble is:
 (a) $\frac{1}{5}$ (b) $\frac{1}{10}$ (c) $\frac{1}{4}$ (d) $\frac{4}{5}$
73. The probability of an impossible event is:
 (a) $\frac{1}{2}$ (b) 1 (c) 0 (d) $\frac{1}{4}$
74. What is the probability that a number selected from numbers 1, 2, 3, ..., 30, is a prime number, when each of the given numbers is equally likely to be selected?
 (a) $\frac{1}{2}$ (b) $\frac{1}{4}$ (c) $\frac{2}{3}$ (d) $\frac{1}{3}$
75. What is the probability of occurrence of non-leap year having 53 Sundays?
 (a) $\frac{2}{7}$ (b) $\frac{1}{5}$ (c) $\frac{1}{7}$ (d) $\frac{1}{6}$

BIOLOGY

76. Which of the following are unicellular organisms
 A) amoeba (b) chloella (c) Paramecium (d) all of the above
77. Which of the following is the connecting link between annelida and arthropoda?
 A) Peripatus (b) Lungfish (c) Duck-billed platypus (d) Petromyzon
78. Which of the following cells can be produced by mitosis ?
 A) Somatic cell (b) Gametes (c) Stem Cells (d) Both A and C
79. Our muscles cells can performtype of respiration during exercise
 A) aerobic respiration (b) anaerobic respiration (c) Fermentation (d) Both B and C
80. Which of the following is not a step of anerobic respiration ?
 A) Glycolysis (b) Fermentation (c) TCA (d) Both A and B
81. At the time of birth , there are _____oocytes in the ovary of a female foetus
 A) 1 to 2 million (b) 2 to 3 million (c) 2 to 4million (d) none of these
82. Length of a sperm
 A) 10 micrometer (b) 30 micrometer (c) 50 micrometer (d) 60 micrometer

83. Which of the following is an endangered species ?
 A) Lion-tailed macaque
 B) Shekru
 C) Tigers
 D) All of the above
84. Which organization prepared the 'Red List 'that contain the name of endangered species from different countries.
 A) IUCN
 B) UNICEF
 C) IPCC
 D) UNEP
85. Environmental conservation Act enacted in
 A) 1972
 B) 1982
 C) 1986
 D) 1980
86. Sundarban Sanctuary of West Bengal is reserved for
 A) Rhinos
 B) Asiatic Lions
 C) Tigers
 D) Wild bisons
87. Which of the following species is Indeterminate species ?
 A) Tiger
 B) Giant squirrel
 C) Lesser florican
 D) Red panda
88. Occurrence of diversity among the organism of same species is
 A) Ecosystem diversity
 B) Species diversity
 C) Genetic diversity
 D) Both B and C
89. Which of the following is a hermaphrodite animal?
 A) doliolum
 B) scorpion
 C) centiped
 D) cockroach
90. Which of the following animals can regenerate it's broken body parts ?
 A) Frog
 B) Starfish
 C) Sparrow
 D) Pigeon
91. Which of the following animals body shows bilateral symmetry ?
 A) Starfish
 B) Jellyfiosh
 C) Earthworm
 D) Sponge
92. Only two germs layer are formed in
 A) Cnidarians
 B) Aschelminths
 C) Platyhelminths
 D) Annelida
93. Which of the following are unicellular organisms
 A) amoeba
 B) chloella
 C) paramoecium
 D) all of the above
94. Which of the following is not vestigial organ ?
 A) coccyx
 B) wisdom teeth
 C) appendix
 D) intestine

95. The principal microorganism for yogurt is _____
A) *Leuconostoc citrovorum* C) *Streptococcus thermophilus*
B) *Streptococcus lactis* D) *Lactobacillus acidophilus*
96. Which of the following microorganism is eliminated in canned foods?
A) *Lactobacillus* C) *Mycobacterium tuberculosis*
B) *Clostridium botulinum* D) *Coxiella burnetii*
97. Glycolysis can occur in _____
A) anaerobic cells
B) aerobic cells
C) neither aerobic and anaerobic cells
D) both aerobic and anaerobic cells
98. Protein located in bones is
A) Myosin C) Actin
B) Melanin D) Ossein
99. We get ____ energy from lipids
A) 4 cal/gm C) 9 Kcal/gm
B) 9 cal/gm D) 4 Kcal/gm
100. Find and odd one out
A) Carrot
B) Raddish
C) Potato
D) Sweet potato
-