

**Jayesh Foundation Kalwan**  
**JAYESH FOUNDATION SCHOLARSHIP EXAMINATION 2023**  
**Descriptive Paper (PCB)**

**Time : 3:00 hrs.**

**Max. Marks : 100**

**PHYSICS**

**General Instructions**

- All questions are compulsory.
- This question paper has three sections: Section A, Section B & Section C,
- Section A contains five questions of one mark each, Section B contains four questions of two marks each and Section C Contains four Questions of three marks each.

• **Section (A)**

1. Why is tungsten metal used in bulbs but not in fuse wires?
2. What connection is used in domestic appliances and why?
3. When we see any object through the hot air over the fire, it appears to be wavy, moving slightly. Explain.
4. The magnification produced by a plane mirror is +1. What does it mean?
5. The radius of curvature of convex mirror is 20cm. find focal length and its power.

**Section (B)**

6. Calculate the area of cross section of a wire of length 2m, its resistance is  $25\Omega$  and the resistivity of material of wire is  $1.84 \times 10^{-6} \Omega\text{m}$ .
7. A star sometimes appears brighter and some other times fainter. What is this effect called? State the reason for this effect.
8. Find the current in the given circuit.

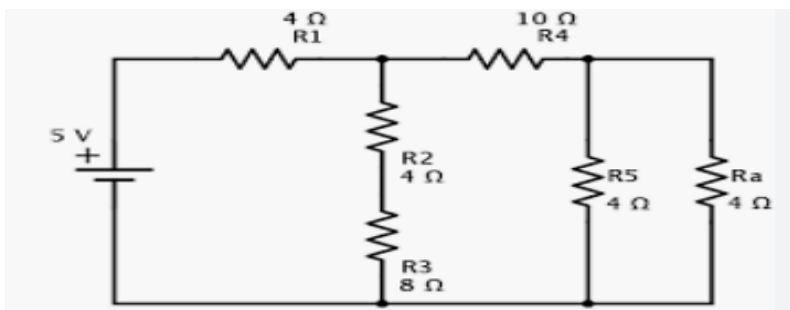

9. A current through a horizontal power line flows in east to west direction. What is the direction of magnetic field at a point directly below it and at a point directly above it? Name the rule you have applied in this case.

## Section (C)

10. A torch bulb is rated at 3V and 600mA. Calculate it's  
(a) Power b) Resistance c) Energy consumed if it is lighted for 4 Hrs.
11. Name three refractive defects of vision with help of diagram. Explain its reasons and correction of these defects.
12. A spherical mirror produces an image of magnification -1 on a screen placed at a distance of 50 cm from the mirror.
- (a) Write the type of mirror.  
(b) Find the distance of the image from the object.  
(c) What is the focal length of the mirror?  
(d) Draw the ray diagram to show the image formation in this case.
13. A student while studying the force experienced by a current carrying conductor in a magnetic Field records the following observation

1	The force experienced by the conductor is increases as the current in the conductor is decreased
2	The force experienced by the conductor is decreases as the strength of magnetic field is decreased
3	Direction of the force on the current carrying conductor is determined suing Fleming Left hand rule

Which of these observations is correct? Explain each observation.

-----

## CHEMISTRY

Each question carries 5 marks

1. Explain mechanism of cleansing action of soap. Write esterification and saponification reaction.
2. From the list given below, select words required to complete the blanks (i) to (v).  
Words should be used only once.  
Hydrogen, hydronium, hydroxide, salt, water.

A solution X turns blue litmus red, so it must contain (i).....ions. Another solution Y turns red litmus blue, so it must contain (ii).....ions. When solution X and Y are mixed ,the product will be (iii)..... and (iv)..... . Also, if a piece of magnesium is put into X, (v)..... gas will be released.

3. (a) Write one example for each of decomposition reaction carried out with help of  
(i) Electricity  
(ii) Heat  
(iii) Light
- (b) Which of the following statements is correct and why?  
(i) Copper can displace silver from silver nitrate  
(ii) Silver can displace copper from copper sulphate solution.
4. (a) Define a balanced chemical equation. Why should an equation be balanced?
- (b) Write the balanced chemical equation for the following reaction:  
(i) Phosphorus burns in presence of chlorine to form phosphorus pentachloride.  
(ii) Burning of natural gas.  
(iii) The process of respiration.
5. (a) Mention the pH range within which our body works. Explain how antacids give relief from acidity. Write the name of one such antacid.
- (b) Fresh milk has a pH of 6. How does the pH will change as it turns to curd? Explain your answer.
- (c) A milkman adds a very small amount of baking soda to fresh milk. Why does this milk take a longer time to set as curd?
- (d) Mention the nature of toothpastes. How do they prevent tooth decay?
- 

## BIOLOGY

### Section (A) (1 MARK)

1. Green and red colored seeds are recessive and dominant trait respectively. Out of F1 and F2 in which generation will the green seed appear, if both parents are not hybrid.
2. Species A shared ten characteristics with species B, species C share fifteen characteristics with D which of the two pairs share closer relation.
3. Name the one unisexual plant.
4. Give one advantage and one disadvantage of ozone.
5. The gap between two neurons is called a .....

### Section (B) (2 MARKS)

6. What is a genetic drift?
7. Why evolution should not be equated with progress?
8. What is the speciation? How does it occur?
9. What is STD? Name two STDs.
10. List any two differences between pollination and fertilization.

11. Why the forests are called as biodiversity hot spots?
12. Dams are constructed on the river for multipurpose use. Give its advantages and disadvantages.
13. How is the movement of leaves of the sensitive plant different from the movement of a shoot towards light?
14. How does our body respond when adrenaline is secreted into the blood?
15. What is the advantage of a four chambered heart?

**Section (C) (3 MARKS)**

16. After the death of two insects, one of the insects was buried in hot mud and the other is usually found mud. Which of the two is more likely to be preserved better and why?
17. Tabulate two distinguishing features between acquired traits and inherited traits with one example of each.
18. Describe in brief the role of (i) testis (ii) seminal vesicle, (iii) vas deferens, (iv) ureter and (v) prostate gland in human male reproductive system
19. Why are pesticides considered as pollutants despite being useful to the farmers?
20. How do auxins promote the growth of a tendril around a support?

**Section (D) (5 MARKS)**

21. What are the various evidences in factors of evolution?
  22. A cross was made between pure breeding pea plants one with round and green seeds and the other with wrinkled and yellow seeds.
    - (a) Write the phenotype of F1 progeny. Give reason for your answer.
    - (b) Write the different types of F2 progeny obtained along with their ratio when F1 progeny was sealed.
-